



ALTUS

TONEARM

USER MANUAL



SCAN HERE FOR
VIDEO GUIDE



Table of Contents

| Section | Page | Section | Page |
|-----------------------------------|------|--------------------|------|
| Introduction | 4 | Bias Adjustment | 9 |
| Warnings | 4 | Arm Lift notes | 9 |
| Packaging | 4 | Static Charge | 9 |
| Parts Checklist | 4 | Specifications | 10 |
| Parts Identification | 5 | Cleaning | 10 |
| Tonearm Fitting Options | 6 | Servicing | 10 |
| Fitting tonearm to mounting | 6 | Warranty Statement | 10 |
| Cartridge Installation and Set Up | 7 | | |

Extended 5-Year Warranty

AVID is pleased to extend the normal warranty duration to 5-Years from the date of original factory shipping.
Register your product at: www.avidhifi.com/register

Introduction

Please take time to read this Instruction Manual before unpacking your Altus tonearm.

This product is meticulously engineered and damage is unlikely with careful handling.

Whilst it is likely that the retailer will install this tonearm, this instruction manual has presumed the customer buying this product has some degree of understanding about tonearms, however if in any doubt, you should contact your retailer.

Warnings

1. Do not expose the tonearm to liquids or moisture.
2. Do not adjust any screw that is highlighted as 'DO NOT TOUCH' on the Parts Identification page (5).
3. The tonearm bearings are precision adjusted and should not be tampered with under any circumstances.
4. When transporting the tonearm the counter weight should be removed.
5. The internal wiring should not be tampered with and the 5 pin DIN connector not removed.

Packaging

The packaging is expensive to replace, so save all the packing in a dry place away from fire hazard.

The Altus tonearm is a precision instrument and the packaging has been especially designed so that all component parts are safe during transportation. If you should need to return your unit for service or repair, you will be required to use the original packaging to keep it safe from damage. In the event of the packing being lost or damaged further packing can be provided at cost.

Parts Check List

| | | | | | |
|----------------------|---|-------------------------|---|---------------------|---|
| Instructions | 1 | Tonearm | 1 | Counter Weight | 1 |
| Arm Cable | 1 | Protractor | 1 | Arm Mounting | 1 |
| 2mm A/F Allen Wrench | 1 | 1.27mm A/F Allen Wrench | 1 | M4x14 Bolt & Washer | 4 |

Parts Identification

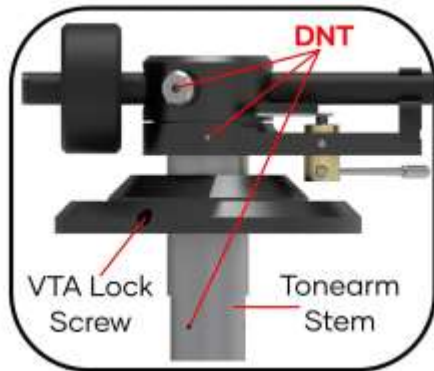
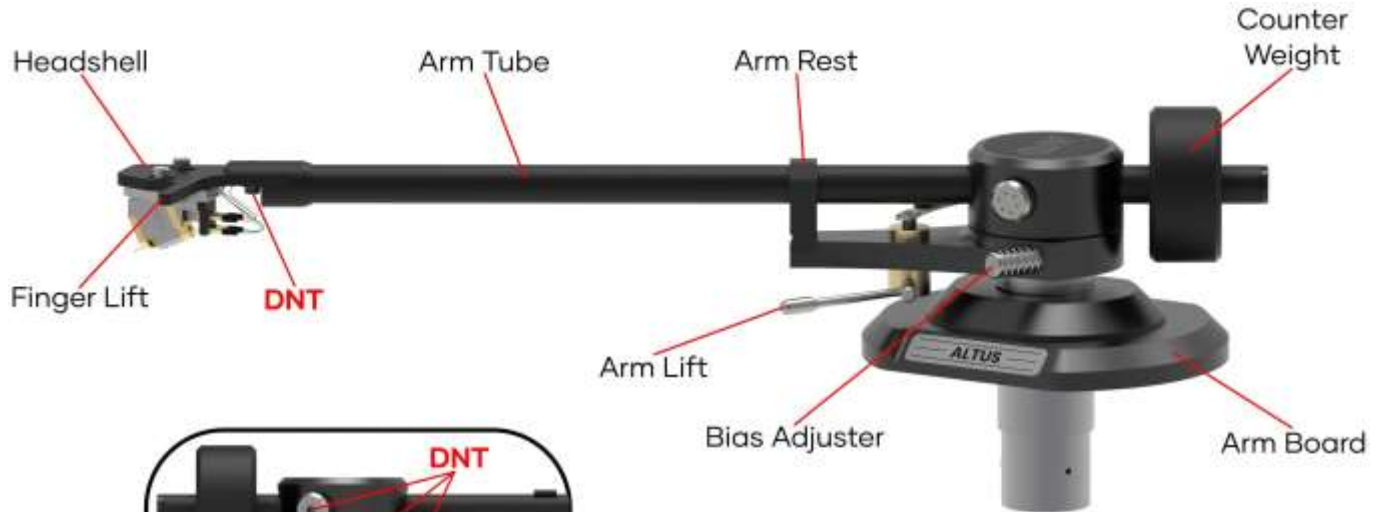

DNT - DO NOT TOUCH

Tonearm fitting Options



AVID TURNTABLE FITTING



SME STYLE FITTING

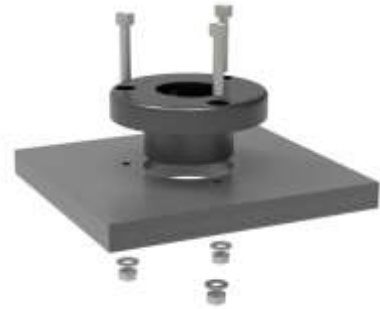

UNIVERSAL FITTING

Three types of fitting option are available, complete with the bolts required to install the tonearm. The tonearm is supplied with the AVID fitting, the other two can be purchased separately.

Fitting Tonearm to Mounting

Insert the tonearm into the mounting, aligning the arm so its positioned forward when in the armrest. Use the 2mm A/F Allen Wrench to lock the arm in position. You do not need excessive force to lock the arm in position. To raise or lower the tonearm height, simply unlock screw, adjust and relock.



Cartridge Installation and Set Up



Attach cartridge to matching colour coded wires, being careful not to touch stylus, keeping the guard on.

The coding is:

Red - Right channel signal
Green- Right channel ground
White- Left channel signal
Blue- Left channel ground

Review cartridge instructions supplied



Fasten the cartridge to the head shell using the provided screws.

For AVID cartridges, position the cartridge approximately 0.2-0.4mm (0.007"-0.15") from the front face of the headshell. Double check this position later with the alignment gauge provided with tonearm.



Twist counter weight onto tonearm making sure not to dislodge the rubber O-Rings.

At this stage, push on so that the tonearm is not applying any down force to the cartridge.



Using suitable scales, adjust the counter weight to achieve correct tracking force as recommended by the cartridge manufacturer.

Scales are not supplied as most audiophiles at this level will have their own personal choice of scale. Your retailer will be able to assist.



Commonly called 'Vertical Tracking Angle' or VTA, adjust the level of the tonearm so that the arm tube is parallel to record surface when stylus is sitting on the record.

For excellent sound, the VTA of the tonearm is a critical adjustment for good sound. We would encourage turntable owners to adjust the angle until the vinyl sounds right.



A poorly aligned cartridge will cause the sound to distort and potentially damage your records.

Called 'Overhang' is set using the alignment gauge supplied to position the cartridge in the headshell for best vinyl playback.

Bias Adjustment

Natural forces pull the tonearm, ever increasingly towards the centre of the record, which left uncorrected can result in mistracking, distorted sound and record damage. Bias compensation, also known as Anti-skate, is the mechanism that counteracts this, and our design, gradually increases the level of force as the tonearm gets closer to the centre, applying increasing compensation as the cartridge spans the record. The amount of bias required depends on various factors such as the shape of the stylus tip and even the record material itself, there is no definitive amount or setting.

To start, we suggest you rotate the bias screw to the end stop and then unwind six full turns. Listening to music with the cartridge approximately two thirds across the record is the most reliable method,. If you notice left channel mistracks, reduce the force and unwind the bias screw, and if you notice the right channel mistakes, increase the force by screwing further in. If you do not trust your ears, a suitable test record can be used to adjust the bias force correctly and also your retailer can give assistance.

Arm Lead

Insert the 5 Pin DIN connector into the tonearm base properly, clicking into place. Create a loop with the lead for suspended turntables and lock it in place. Connect the colour coded plugs and ground cable to the amplifier.

Arm Lift Notes

The lift device does not require any adjustments, but its proper functioning is contingent on the arm-tube being level. Contrary to popular belief, variables such as the height of the cartridge body do not impact the calibration of the lift device. The factory settings of the lift device are designed to work optimally once the arm height has been accurately set. To achieve this, the arm-tube must be parallel to the surface of the record when the cartridge has been lowered onto it. Should the lift or the cue bar need service, a 1.27 A/F Allen wrench is supplied.

To operate the Lift device correctly, begin by raising the lever beyond the vertical position to lift the cartridge above the record's surface. Then, pull the lever downwards gently, in line with the cue holder, without applying excessive pressure or pushing it any further as it can cause the internal cam to lock. If the device stops descending before the stylus lands on the record surface, you may need to lift the arm lift slightly to assist the process.

Static Charge

Static charge can build up on the arm, causing noise when touching the finger lift, especially in dry or air-conditioned environments. Solutions include adding moisture to the air with a plant, wiping the arm with an antistatic fluid like L'art du Son, and avoiding synthetic materials.

Specifications

| | | |
|----|-------------------------|--------|
| 1. | Effective Length | 233 mm |
| 2. | Mounting Distance | 216 mm |
| 3. | Offset Angle | 23° |
| 4. | Overhang | 17 mm |
| 5. | Effective Mass | 15g |
| 6. | Cartridge Balance range | 5-13g |
| 7. | Weight | 680g |

Cleaning

To clean the tonearm, it is advisable to use a soft micro-fiber cloth. Avoid using any abrasives or solvents as they can cause damage.

Servicing

Before seeking any servicing or repair for an AVID product, we recommend that you first get in touch with your dealer or distributor. Alternatively, you can contact AVID directly and we will provide you with information on the nearest service location.

Warranty Statement

AVID HiFi Limited products are warranted against defects in materials and workmanship for a period of two years from the original date of purchase, or no later than three years from the date of shipment to an authorized AVID agent, whichever comes first, extending to five years subject to the product owner having submitted the online Registration form:

www.avidhifi.com/register

The warranty becomes void if the tonearm has been modified, received maltreatment of any kind and excludes general wear and tear.

Should you need to return the tonearm, you must first complete our 'Product Returns' application on our website or contact us before any return is made, and it must be packed in the original packing and returned to AVID HiFi at the customer's expense. AVID HiFi reserves the right to charge for examination and return freight.

Full details of our Warranty and Terms and Conditions can be found on our website.





AVIDHIFI



AVID HIFI Ltd

Bicton Industrial Park, Kimbolton, Huntingdon,
Cambridgeshire. PE28 0LW ENGLAND

Tel: +44(0)1480 869 900 — Website: www.avidhifi.com - Email: info@avidhifi.co.uk
Company Registered No: 05435528 — VAT Registration No: GB 694 9858 48 — Directors: C. Mas & S.J. Mas